

Bridge Sink Mixer

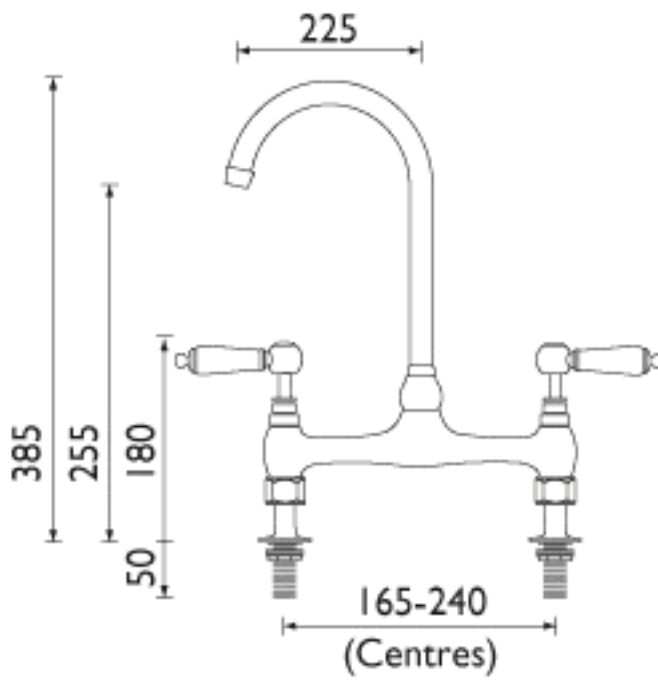

Note: Wall mount version has 210mm fixed Centres

Renaissance

Bridge Sink Mixer

INSTALLATION

1. Identify all components and check for completeness, particularly before arranging fitting.
2. Fit the spout to the body and secure using grub screw at the rear of the body.
3. Fit the mixer to the sink using the washers and backnuts provided.
4. Fit check valve supplied to the hot side (arrow on valve points upwards), and then connect the hot and cold water supplies.
5. Fully open both valves, letting them run for a few minutes to flush out the system.
6. Check all joints and connections for leaks.

MAINTENANCE

If the fitting begins to drip:

1. Turn off water supply.
2. Remove fitting handle, valve cover and valve.
3. Carefully clean seating and rubber washer.
4. Replace valve, valve cover and handle, and turn on the water supply.
5. Contact our helpline if problem persists.

WATER PRESSURE

This mixer is suitable for use at all supply pressures. However for optimum use both the hot and cold supplies should be reasonably balanced.

If the fitting is installed at low pressure (tank fed), then the minimum distance from the outlet of the nizzle to the underside of the cold tank should be 1.8 metre to ensure adequate performance.

This mixer should be installed in compliance with the water Byelaws.

Where the supplies are balanced, i.e. hot water from cylinder tank / cold from mains the check valve supplied must be fitted to the hot supply pipe.

For details contact your local water authority.

AFTERCARE INSTRUCTIONS

Your fitting has a high quality finish and should be treated with care to preserve the visible surfaces.

All surface finishes will wear if not cleaned correctly, the only safe way to clean your mixer is to wipe with a soft damp cloth. Stains can be removed using washing up liquid. All bath cleaning powders and liquids will damage the surface of your fitting even the non-scratch cleaners.